

**Package Outline Dimensions**

U-DFN2020-8 (Type A)

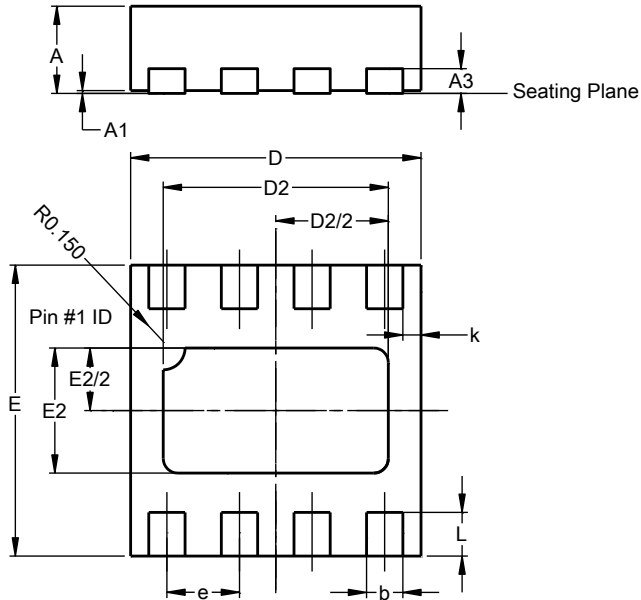

U-DFN2020-8 (Type A)			
Dim	Min	Max	Typ
A	0.570	0.630	0.600
A1	0	0.05	0.02
A3	-	-	0.152
b	0.20	0.30	0.25
D	1.950	2.075	2.00
D2	1.45	1.65	1.55
e	0.500 BSC		
E	1.950	2.075	2.00
E2	0.76	0.96	0.86
k	-	-	0.125
L	0.250	0.350	0.300
<b>All Dimensions in mm</b>			

**Suggested Pad Layout**

U-DFN2020-8 (Type A)

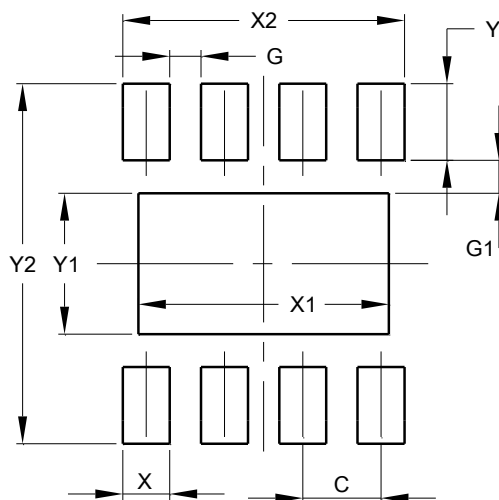

Dimensions	Value (in mm)
C	0.500
G	0.200
G1	0.210
X	0.300
X1	1.600
X2	1.800
Y	0.490
Y1	0.900
Y2	2.300

**ALL DIMENSIONS ARE NOMINAL VALUES SHOWN IN MILLIMETERS**

Note: The suggested land pattern dimensions have been provided for reference only, as actual pad layouts may vary depending on application. These numbers may be modified based on user equipment capability or fabrication criteria. A more robust pattern may be desired for wave soldering and is calculated by adding 0.2 mm to the 'Z' dimension. For further information, please reference document IPC-7351A, Naming Convention for Standard SMT Land Patterns, and for International grid details, please see document IEC, Publication 97.