

**Precision Voltage Supervisory Circuit
and 16K I²C Memory**

3 and 5 Volt Systems

FEATURES

- **Precision Dual Voltage Monitor**
 - Automatic V_{CC} Supply Monitor
 - Dual reset outputs for complex microcontroller systems
 - Integrated memory write lockout function
 - No external components required
- **Second voltage monitor output**
 - Separate V_{LOW} output
 - Generates interrupt to MCU
 - Generates RESET for dual supply systems
 - Guaranteed output assertion to V_{CC} ≤ 1V
- **Memory Internally Organized 2K X 8**
 - Two Wire Serial Interface (I²C™)
- **High Reliability**
 - Endurance: 1,000,000 erase/write cycles
 - Data retention: 100 years
- **8-Pin PDIP or SOIC Packages**

OVERVIEW

The S4261 is a precision power supervisory circuit. It automatically monitors the device's V_{CC} level (3V or 5V) and will generate a reset output on two complementary open drain outputs. In addition to the V_{CC} monitoring, the S4261 also provides a second voltage comparator input. This input has an independent open drain output that can be wire-OR'ed with the RESET I/O or it can be used as a system interrupt.

The S4261 also has an integrated 16K-bit nonvolatile memory. The memory conforms to the industry standard two-wire serial interface.

BLOCK DIAGRAM

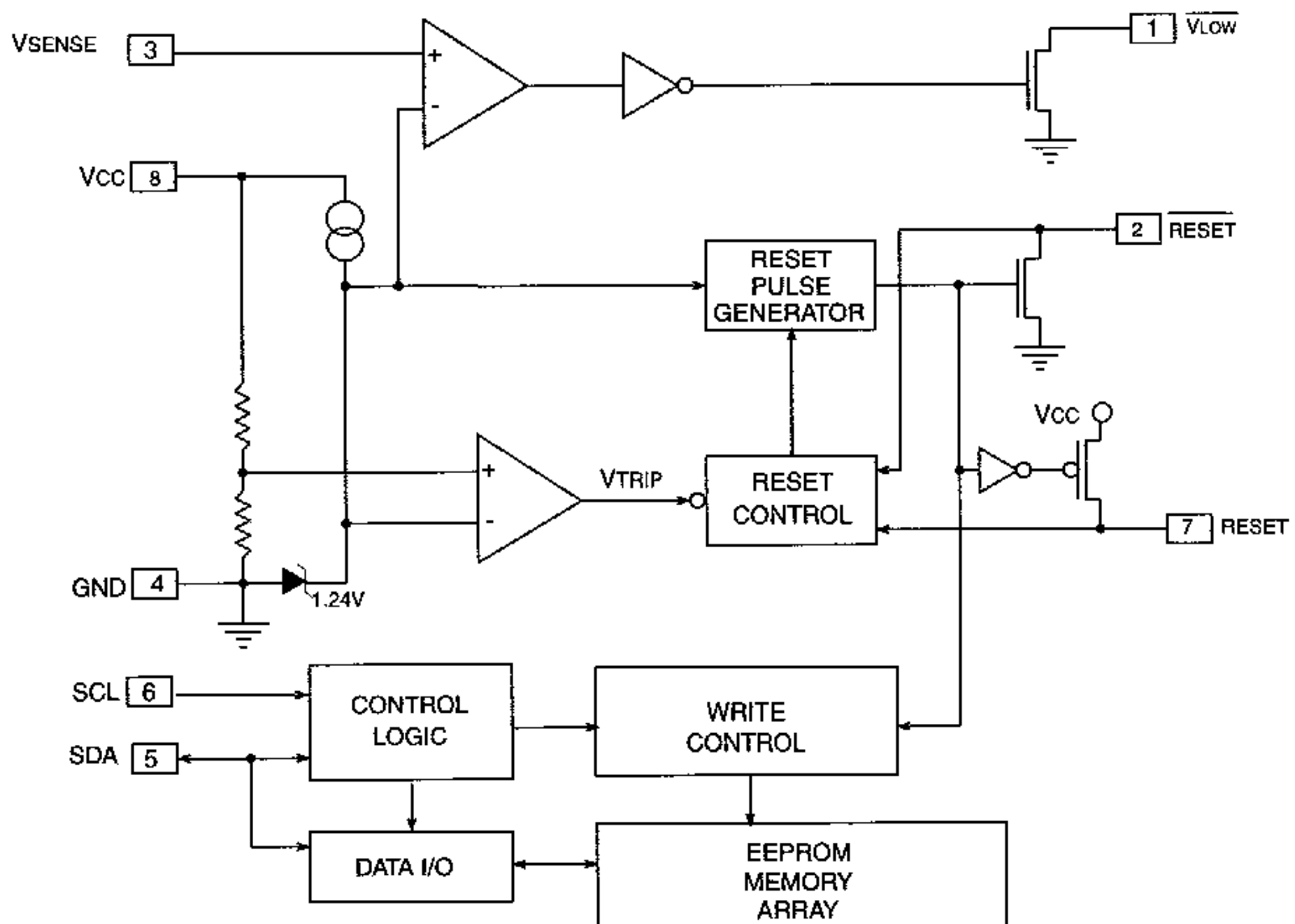

2032 ILL2.0