

General Description

The LP2950 and LP2951 are micropower voltage regulators with very low dropout voltage (typically 40mV at light loads and 380mV at 100mA), and very low quiescent current (75µA typical). The quiescent current of the LP2950/LP2951 increases only slightly in dropout, thus prolonging battery life. This feature, among others, makes the LP2950 and LP2951 ideally suited for use in battery-powered systems.

Available in a 3-Pin TO-92 package, the LP2950 is pin-compatible with the older 5V regulators. Additional system functions, such as programmable output voltage and logic-controlled shutdown, are available in the 8-pin DIP and 8-pin SOIC versions of the LP2951.

Applications

- Automotive Electronics
- Voltage Reference
- Avionics

Features

- High accuracy 5V, guaranteed 100 mA output
- Extremely low quiescent current
- Low-dropout voltage
- Extremely tight load and line regulation
- Very low temperature coefficient
- Use as regulator or reference
- Needs only 1µF for stability
- Current and thermal limiting

LP2951 Versions Only

- Error flag warns of output dropout
- Logic-controlled electronic shutdown
- Output programmable from 1.24 to 29V

Block Diagram and Pin Configurations

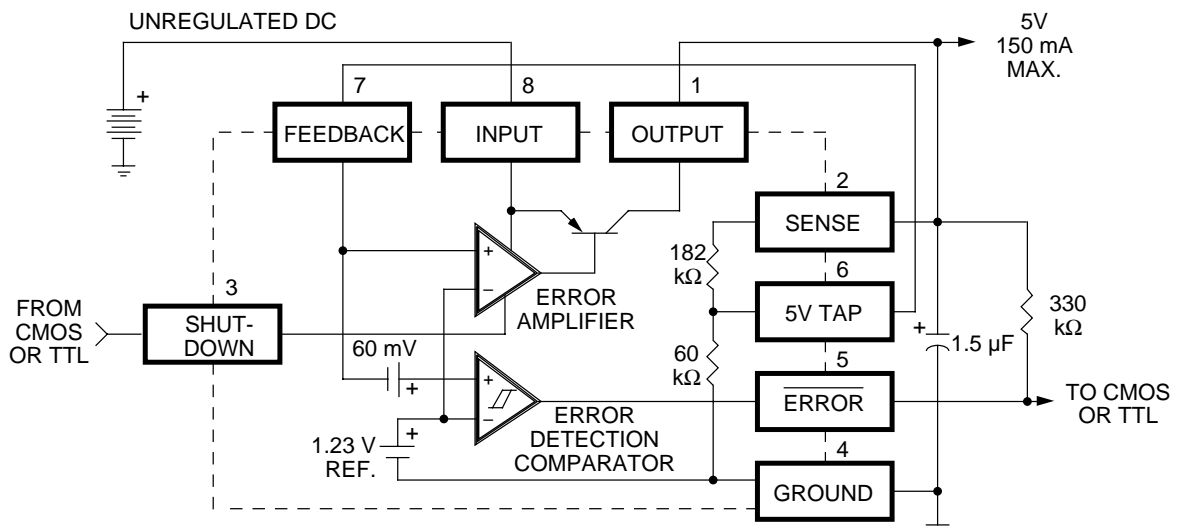

LP2950 and LP2951 Block Diagram
(Pin Numbers Refer to LP2951)

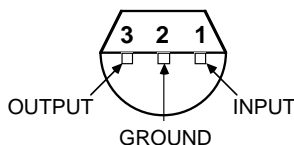

TO-92 Plastic Package Bottom View
(BZ)

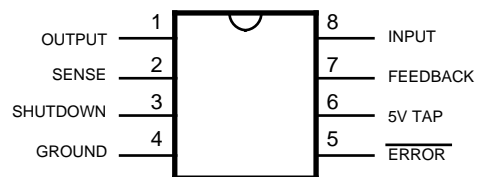

DIP and SO Packages
(BN and BM)

See MIC2950 for a part with 1) higher output (150 mA), 2) transient protection (60V), and 3) reverse input protection to -20V