



Integrated Device Technology, Inc.

CMOS ASYNCHRONOUS FIFO

2048 x 9, 4096 x 9,
8192 x 9 and 16384 x 9

IDT7203
IDT7204
IDT7205
IDT7206

FEATURES:

- First-In/First-Out Dual-Port memory
- 2048 x 9 organization (IDT7203)
- 4096 x 9 organization (IDT7204)
- 8192 x 9 organization (IDT7205)
- 16384 x 9 organization (IDT7206)
- High-speed: 12ns access time
- Low power consumption
 - Active: 770mW (max.)
 - Power-down: 44mW (max.)
- Asynchronous and simultaneous read and write
- Fully expandable in both word depth and width
- Pin and functionally compatible with IDT720X family
- Status Flags: Empty, Half-Full, Full
- Retransmit capability
- High-performance CMOS technology
- Military product compliant to MIL-STD-883, Class B
- Standard Military Drawing for #5962-88669 (IDT7203), 5962-89567 (IDT7203), and 5962-89568 (IDT7204) are listed on this function
- Industrial temperature range (-40°C to +85°C) is available, tested to military electrical specifications

DESCRIPTION:

The IDT7203/7204/7205/7206 are dual-port memory buffers with internal pointers that load and empty data on a first-in/first-out basis. The device uses Full and Empty flags to prevent data overflow and underflow and expansion logic to allow for unlimited expansion capability in both word size and depth.

Data is toggled in and out of the device through the use of the Write (\bar{W}) and Read (\bar{R}) pins.

The devices 9-bit width provides a bit for a control or parity at the user's option. It also features a Retransmit (\bar{RT}) capability that allows the read pointer to be reset to its initial position when \bar{RT} is pulsed LOW. A Half-Full Flag is available in the single device and width expansion modes.

The IDT7203/7204/7205/7206 are fabricated using IDT's high-speed CMOS technology. They are designed for applications requiring asynchronous and simultaneous read/writes in multiprocessing, rate buffering, and other applications.

Military grade product is manufactured in compliance with the latest revision of MIL-STD-883, Class B.

5

FUNCTIONAL BLOCK DIAGRAM

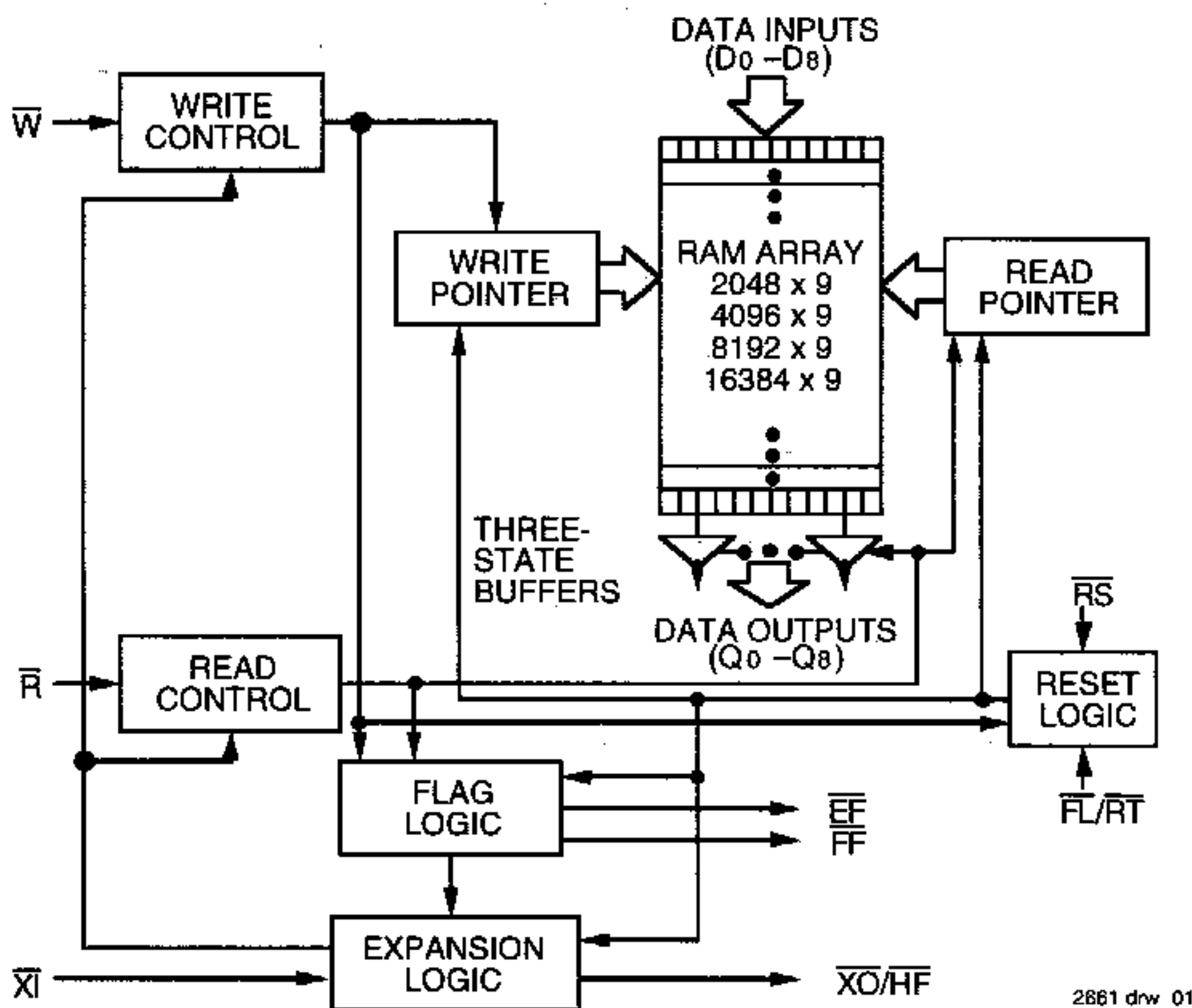

2861 drw 01

The IDT logo is a registered trademark of Integrated Device Technology, Inc.

MILITARY AND COMMERCIAL TEMPERATURE RANGES

DECEMBER 1996