

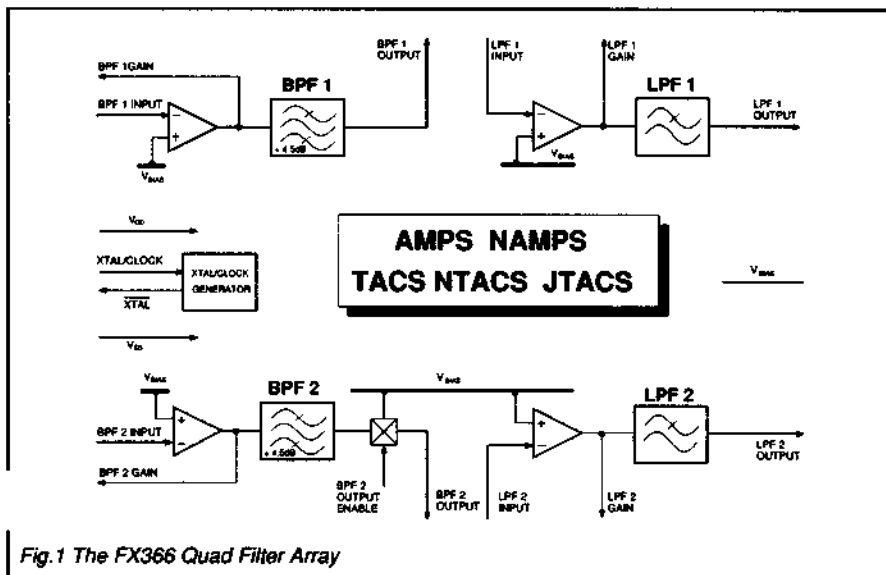

Features/Applications

- Separate Bandpass and Lowpass Gain/Filter Blocks
- Global AMPS/TACS Cellular Applications
- Bandpass Filters
4.5dB Gain (300Hz to 3000Hz)
- Lowpass Filters (3000Hz)
- Input Gain Adjustments
- Output Enable/Mute for Squelch Functions
- Small Outline Surface Mount and DIL Packages
- Low-Power 5V CMOS



FX366

Fig.1 The FX366 Quad Filter Array

Brief Description

The FX366 AMPS/TACS Quad Filter Array comprises 4 separate individual filter/gain blocks in a single microcircuit, containing:

- 2 Bandpass Filters BPF 1 and BPF 2.
 - 14th order 300Hz to 3000Hz -
- 2 Lowpass Filters LPF1 and LPF 2.
 - 10th order 3100Hz -

Each filter block has an amplifier at its input for use with external components to provide functions such as, level adjustment, pre- or de-emphasis and limiting.

BPF 2 has the added facility of Output Enable which could be used as 'audio mute' in a squelch or Inband-Mixing environment.

The provision of 2 bandpass and 2 lowpass filter sections allows 2 audio channels, each of LPF and BPF pairing for use in a full-duplex Tx/Rx cellular system.

All on-chip filters meet the AMPS and TACS cellular system speechband specifications; Including NAMPS, NTACS and JTACS. Switched capacitor filter technology is employed on this chip with all switching clocks derived from an externally applied single Xtal/clock source.

These simple, comprehensive amplifier/filter combinations eliminate the need for several separate integrated circuits therefore saving power and space.

The FX366 is a low-power, single 5V CMOS device and is available in a 22-pin cerdip Dual-in-Line and a 20-pin plastic Small Outline (S.O.I.C.) surface mount package.