

# 3966

## DUAL FULL-BRIDGE PWM MOTOR DRIVER

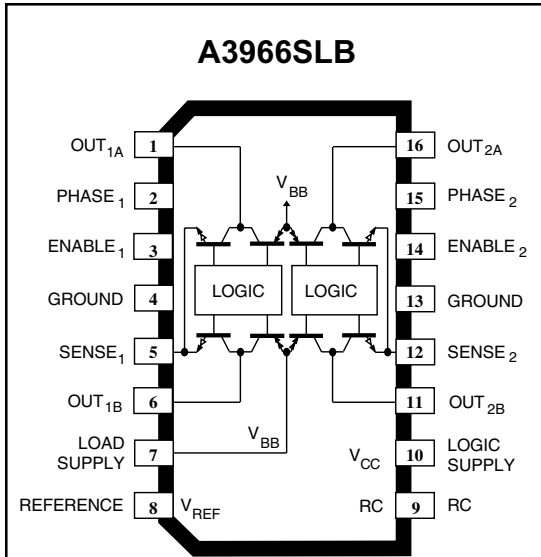

Dwg. PP-066-1

### ABSOLUTE MAXIMUM RATINGS

Load Supply Voltage, $V_{BB}$ .....	<b>30 V</b>
Output Current, $I_{OUT}$ (peak) .....	<b><math>\pm 750</math> mA</b>
(continuous) .....	<b><math>\pm 650</math> mA</b>
Logic Supply Voltage, $V_{CC}$ .....	<b>7.0 V</b>
Input Voltage, $V_{in}$ .....	<b>-0.3 V to <math>V_{CC} + 0.3</math> V</b>
Sense Voltage, $V_S$ .....	<b>1.0 V</b>
Package Power Dissipation ( $T_A = 25^\circ\text{C}$ ), $P_D$	
A3966SA .....	<b>2.08 W*</b>
A3966SLB .....	<b>1.87 W*</b>
Operating Temperature Range,	
$T_A$ .....	<b><math>-20^\circ\text{C}</math> to <math>+85^\circ\text{C}</math></b>
Junction Temperature,	
$T_J$ .....	<b><math>+150^\circ\text{C}</math></b>
Storage Temperature Range,	
$T_S$ .....	<b><math>-55^\circ\text{C}</math> to <math>+150^\circ\text{C}</math></b>

Output current rating may be limited by duty cycle, ambient temperature, and heat sinking. Under any set of conditions, do not exceed the specified current rating or a junction temperature of  $150^\circ\text{C}$ .

\* Per SEMI G42-88 Specification, *Thermal Test Board Standardization for Measuring Junction-to-Ambient Thermal Resistance of Semiconductor Packages.*

The A3966SA and A3966SLB are designed to drive both windings of a two-phase bipolar stepper motor. Each device includes two H-bridges capable of continuous output currents of  $\pm 650$  mA and operating voltages to 30 V. Motor winding current can be controlled by the internal fixed-frequency, pulse-width modulated (PWM), current-control circuitry. The peak load current limit is set by the user's selection of a reference voltage and current-sensing resistors. Except for package style and pinout, the two devices are identical.

The fixed-frequency pulse duration is set by a user-selected external RC timing network. The capacitor in the RC timing network also determines a user-selectable blanking window that prevents false triggering of the PWM current-control circuitry during switching transitions.

To reduce on-chip power dissipation, the H-bridge power outputs have been optimized for low saturation voltages. The sink drivers feature Allegro's patented Satlington™ output structure. The Satlington outputs combine the low voltage drop of a saturated transistor and the high peak current capability of a Darlington.

For each bridge, a PHASE input controls load-current polarity by selecting the appropriate source and sink driver pair. For each bridge, an ENABLE input, when held high, disables the output drivers. Special power-up sequencing is not required. Internal circuit protection includes thermal shutdown with hysteresis, ground-clamp and flyback diodes, and crossover-current protection.

The A3966SA is supplied in a 16-pin dual in-line plastic package. The A3966SLB is supplied in a 16-lead plastic SOIC with copper heat sink tabs. The power tab is at ground potential and needs no electrical isolation.

### FEATURES

- $\pm 650$  mA Continuous Output Current
- 30 V Output Voltage Rating
- Internal Fixed-Frequency PWM Current Control
- Satlington™ Sink Drivers
- User-Selectable Blanking Window
- Internal Ground-Clamp & Flyback Diodes
- Internal Thermal-Shutdown Circuitry
- Crossover-Current Protection and UVLO Protection

Always order by complete part number:

Part Number	Package	$R_{\theta JA}$	$R_{\theta JC}$	$R_{\theta JT}$
A3966SA	16-pin DIP	$60^\circ\text{C/W}$	$38^\circ\text{C/W}$	—
A3966SLB	16-lead batwing SOIC	$67^\circ\text{C/W}$	—	$6^\circ\text{C/W}$